



MOBILIARIO
Newform

 siomuebles.com[®]



Índice

05

RECEPTION MIRÓ

11

OPERA

17

MIRÓ

ÍNDICE

25

TOWER EVO

35

KAMOS PLUS

41

KAMOS PURE

Es el concepto de belleza en su esencia.

Los diferentes materiales perfectamente combinados y las fusiones cromáticas, dan como resultado un mueble que cumple con los conceptos de ser acogedor, de ser nuestra tarjeta de presentación y de dar la bienvenida a la visita.

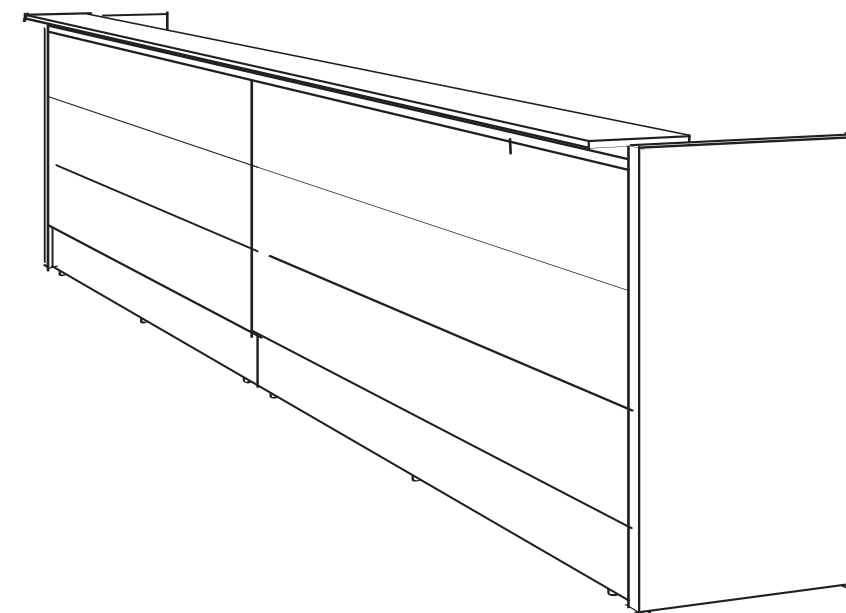

Reception Miró

RECEPTION MIRÓ







Opera es la máxima expresión artística, sea ella musical, teatral o de arte. Cuando se habla de opera se representa un concepto refinado por naturaleza. Así, con esta ambición nació la línea Opera destinada a entendedores con gustos refinados.

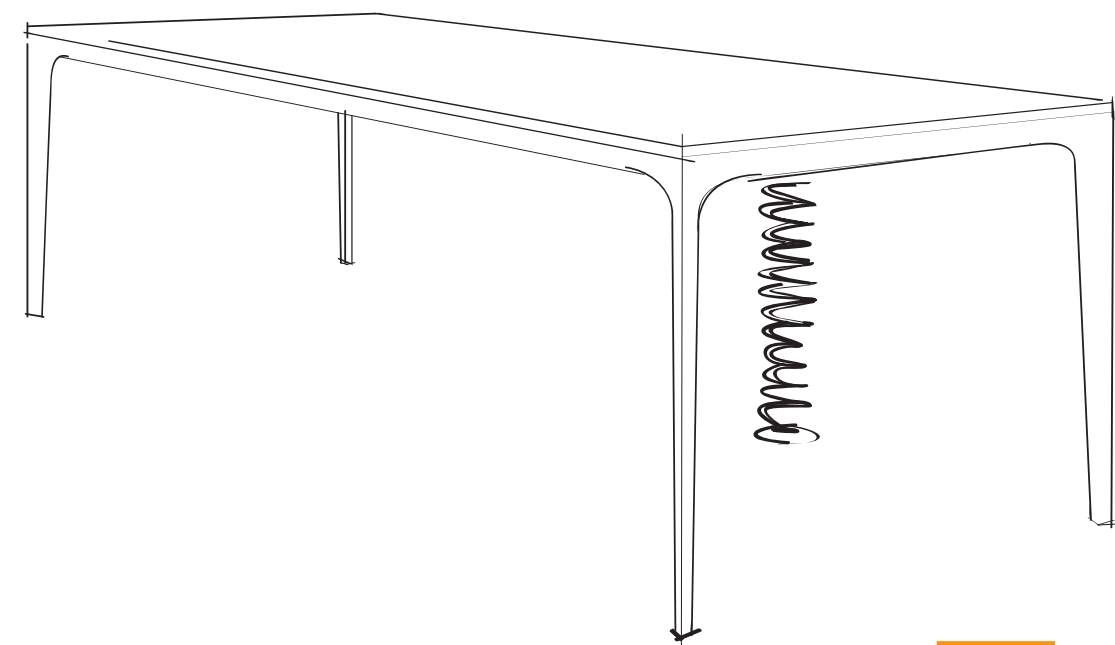

Opera

OPERA



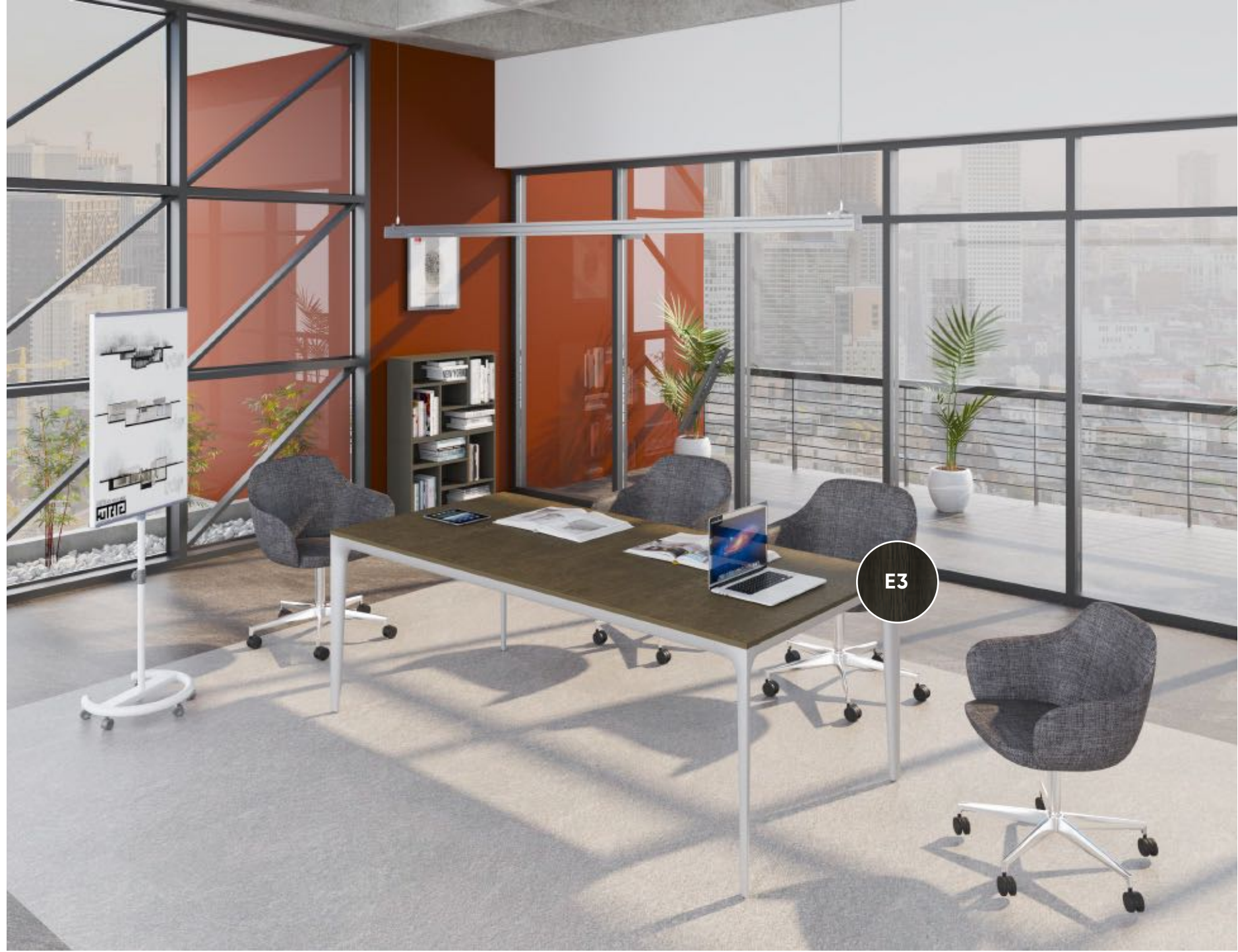



Es la respuesta al deseo de tener algo único, diferente, original. Los materiales y combinaciones cromáticas que ofrece, hacen de Miró un mueble de tendencia que enfatizan el artista encerrado en cada uno de nosotros.



Miró

MIRÓ



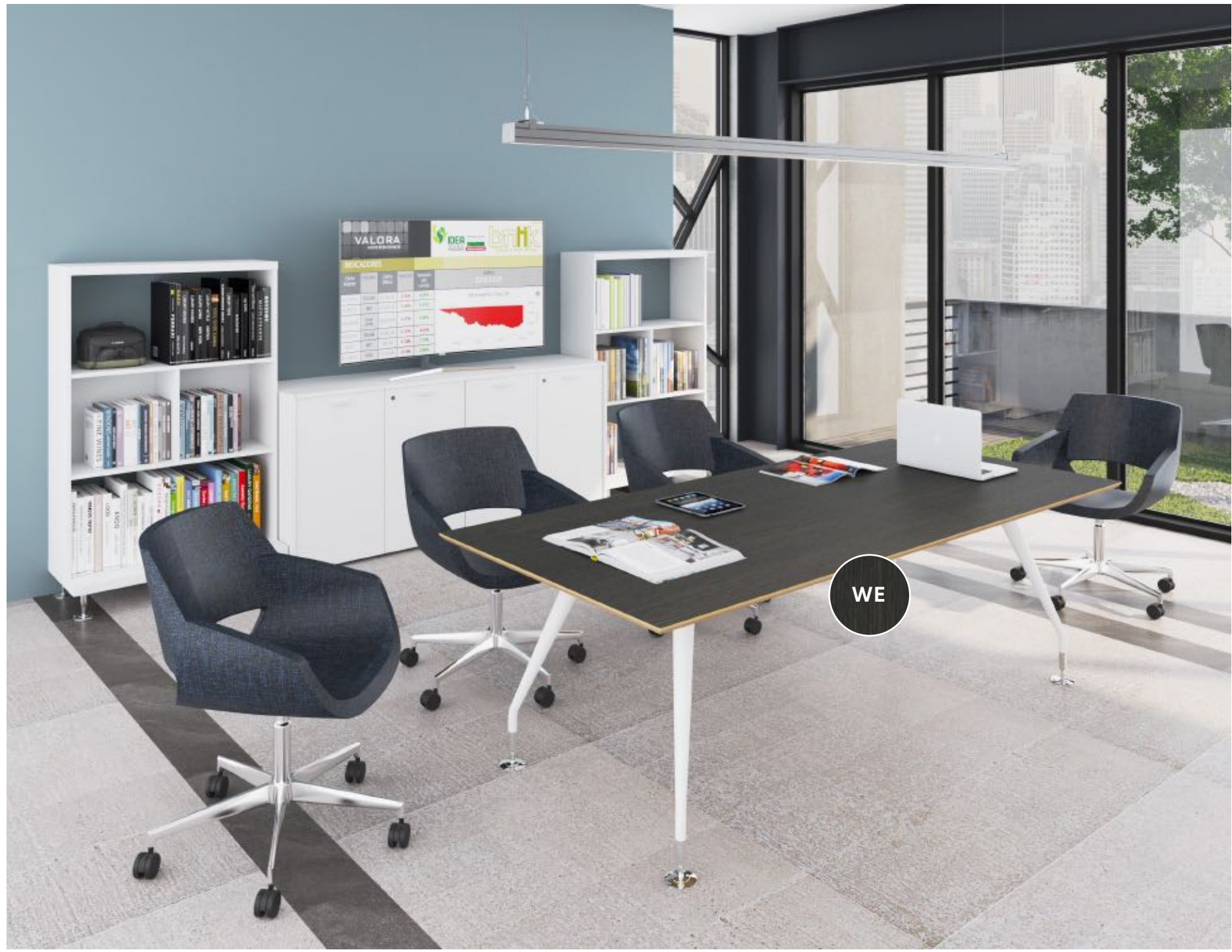
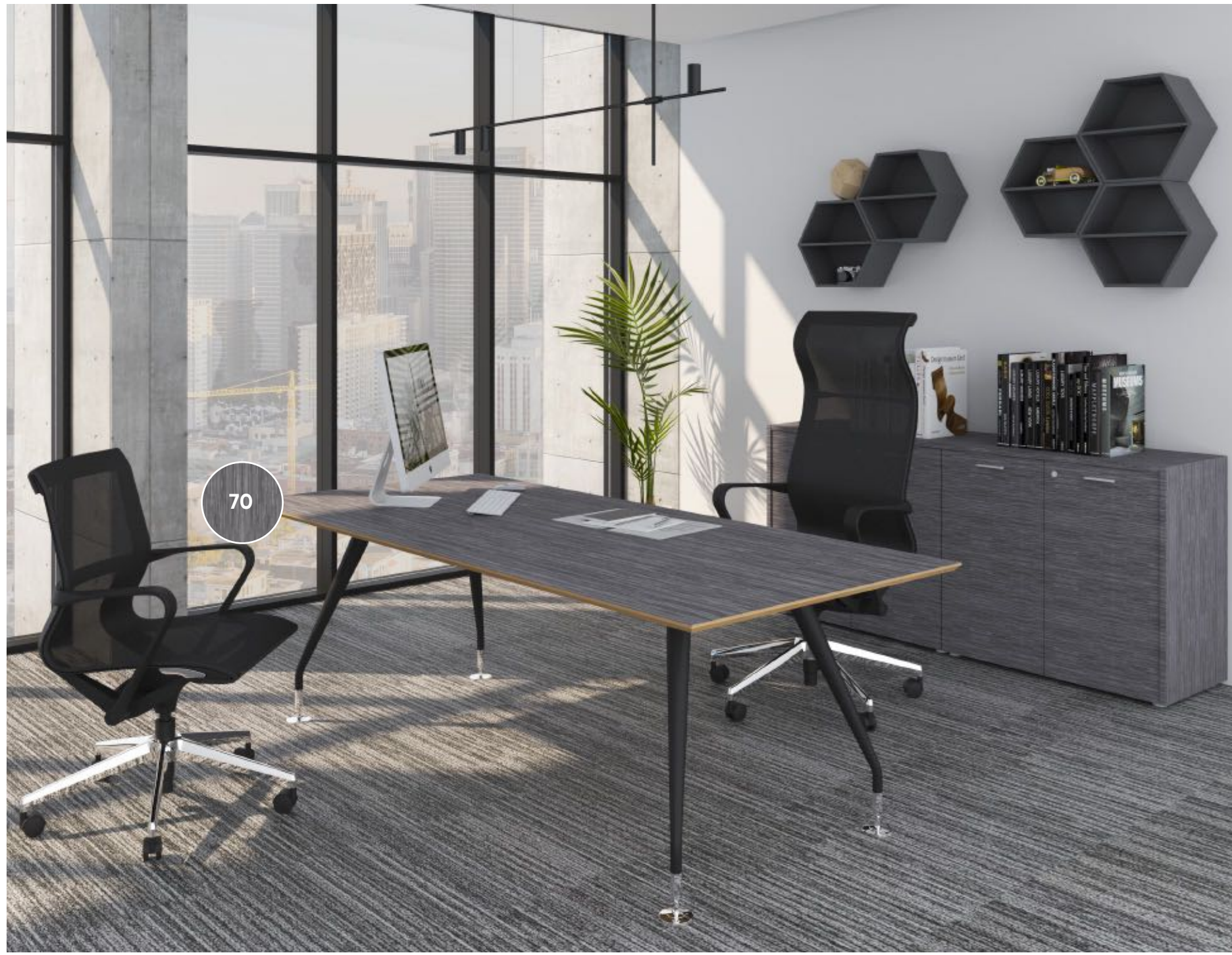



56

56



De una forma arquitectónica sencilla como el trilito, nace Tower Evo, un mueble refinado y con combinaciones cromáticas que lo hacen agradable a la vista. Ideal para espacios destinados a la dirección o gerencia.

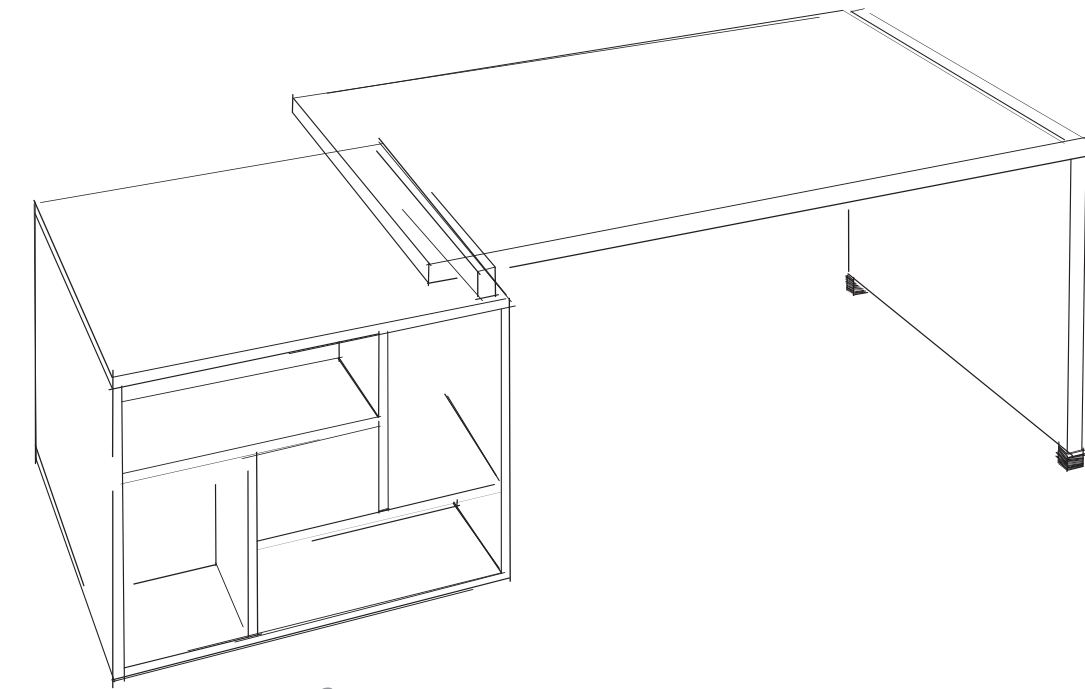

Tower Evo

TOWER EVO





E3



E3







Es la respuesta a la necesidad de muebles económicos pero funcionales y con buen contenido estético. Múltiples soluciones que se adaptan a todo tipo de espacio, amigable hasta en su sistema de armado. Kamos es la solución perfecta para proyectos con presupuesto limitado o con necesidad de entrega rápida.

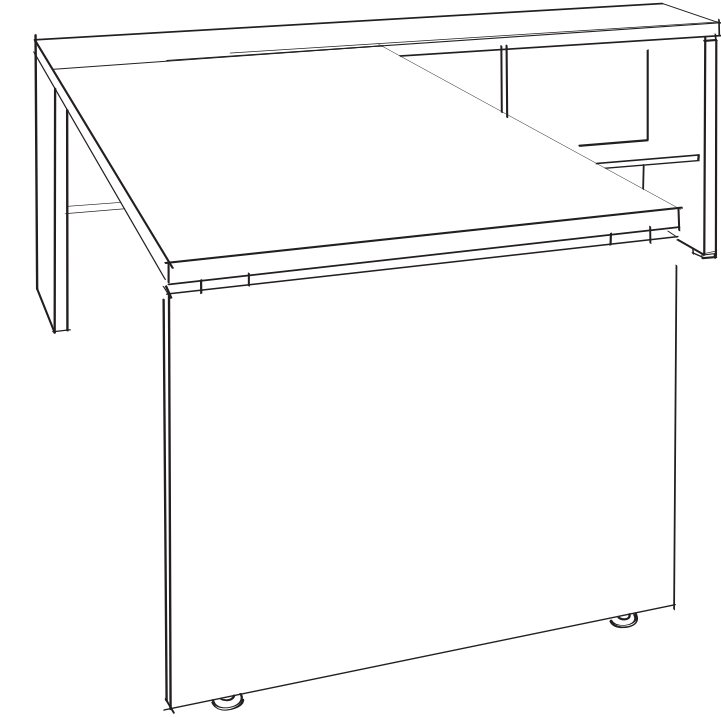

Kamos Plus

KAMOS PLUS







OT

Es la respuesta a la necesidad de muebles económicos pero funcionales y con buen contenido estético. Múltiples soluciones que se adaptan a todo tipo de espacio, amigable hasta en su sistema de armado. Kamos es la solución perfecta para proyectos con presupuesto limitado o con necesidad de entrega rápida.

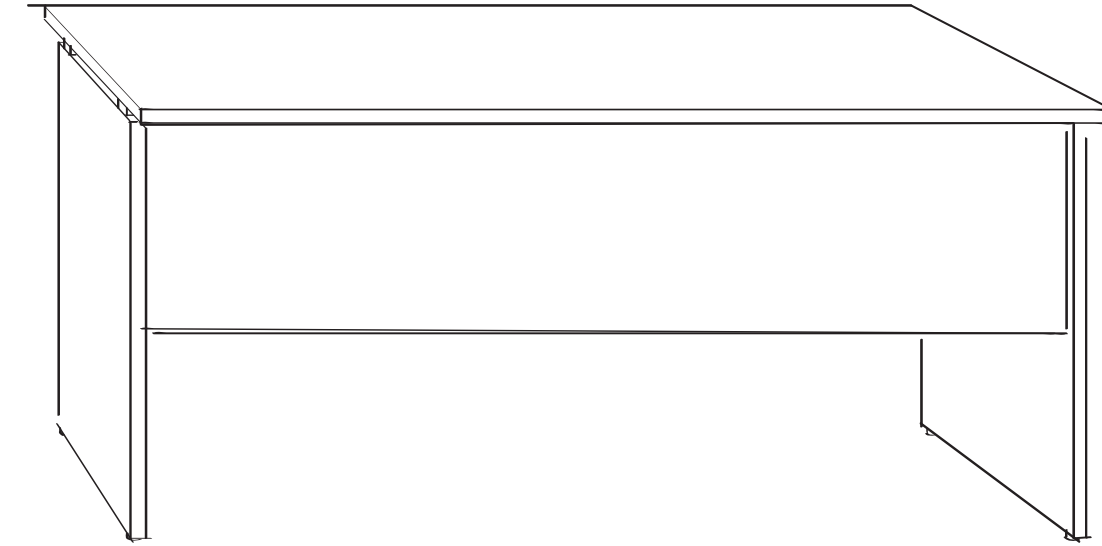

Kamos Pure

KAMOS PURE









OT



OT



RECEPTION MIRÓ

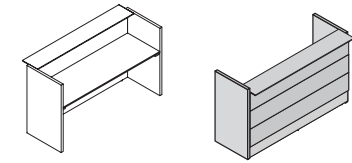

L	1.68 / 2.08
F	0.64
A	1.10

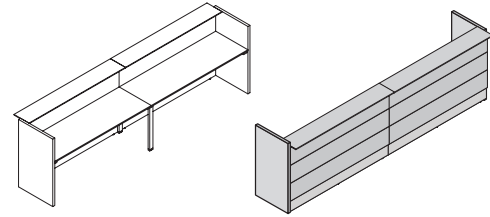

L	3.28 / 4.08
F	0.64
A	1.10

L	=	LARGO
F	=	FONDO
A	=	ALTURA

TOWER EVO

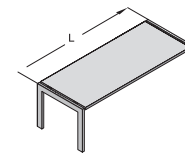

L	1.80
F	0.90

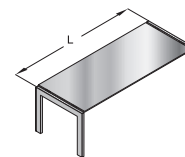

L	1.80
F	0.90

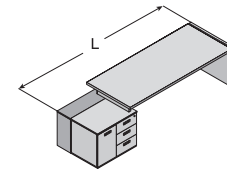

L	2.15
F	0.90

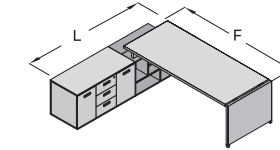

L	2.01
F	2.10

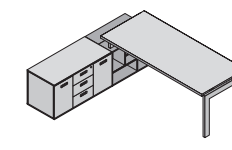

L	2.01
F	2.10

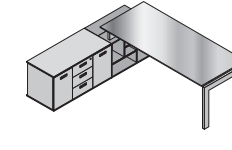

L	2.01
F	2.10



L	0.42
F	0.56
A	0.60

L	=	LARGO
F	=	FONDO
A	=	ALTURA

OPERA

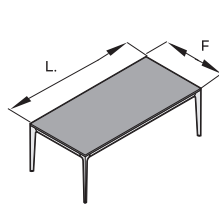

L	2.10
F	1.00

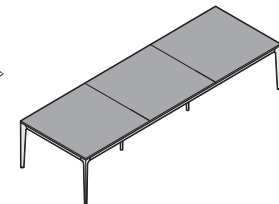

L	3.60 [3 x 1.20]
F	1.20



L	0.42
F	0.56
A	0.60



L	0.81
F	0.27
A	1.17

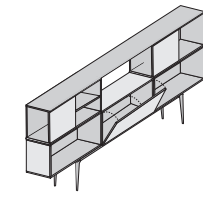

L	2.70
F	0.38
A	1.26

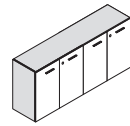

L	1.80
F	0.46
A	0.82

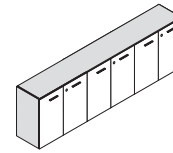

L	2.70
F	0.46
A	0.82

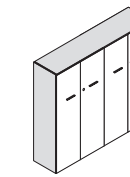

L	1.80
F	0.46
A	1.62

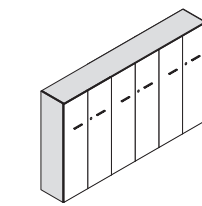

L	2.70
F	0.46
A	1.62

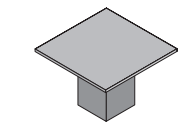

L	1.10
F	1.10

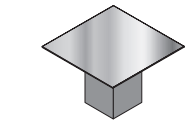

L	1.10
F	1.10

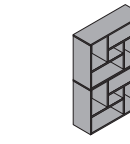

L	0.81
F	0.27
A	1.17

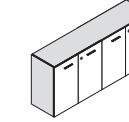

L	1.80
F	0.46
A	0.82

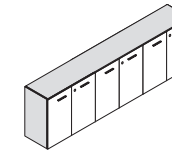

L	2.70
F	0.46
A	0.82

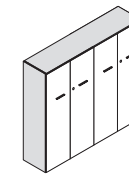

L	1.80
F	0.46
A	1.62

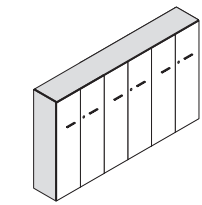

L	2.70
F	0.46
A	1.62

MIRÓ

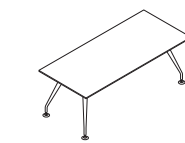

L	1.80 / 2.00
F	0.90

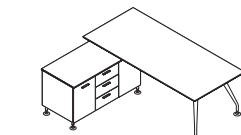

L	1.80 / 2.00
F	1.80

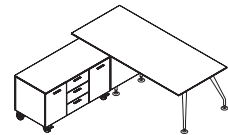

L	2.00
F	1.95

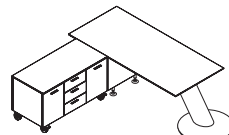

L	2.00
F	1.95



L	0.43
F	0.53
A	0.66

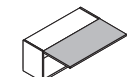

L	0.90
F	0.33
A	0.44



L	0.90
F	0.33
A	0.44

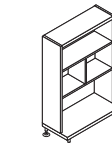

L	0.90
F	0.31 / 0.44
A	1.42

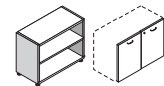

L	0.90
F	0.46
A	0.82

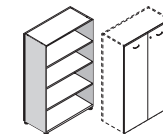

L	0.90
F	0.46
A	1.62

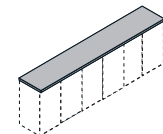

L	0.90 / 1.80
F	2.25 / 2.70

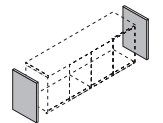

A	0.80
---	------

KAMOS PLUS

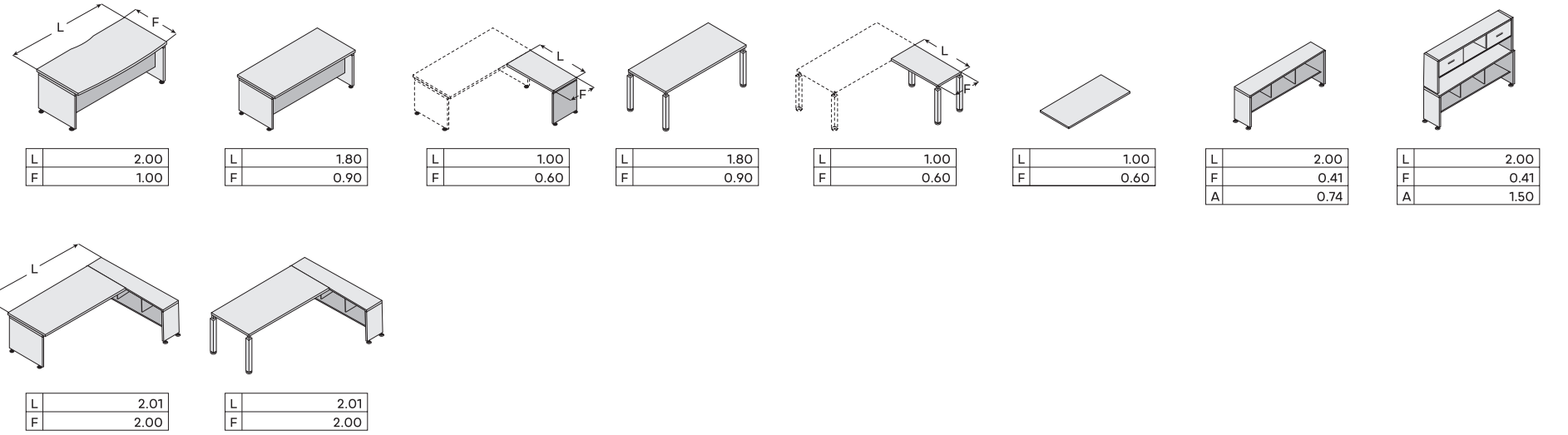

L	=	LARGO
F	=	FONDO
A	=	ALTURA

ELEMENTOS COMPARTIDOS KAMOS PLUS & PURE

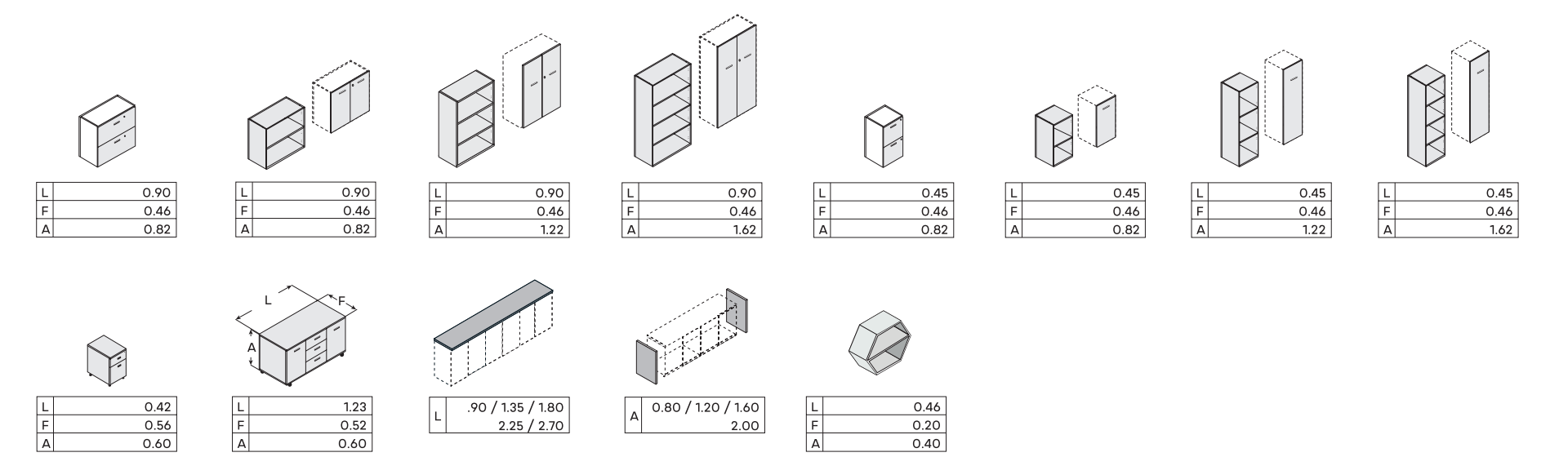

L	=	LARGO
F	=	FONDO
A	=	ALTURA

KAMOS PURE

